

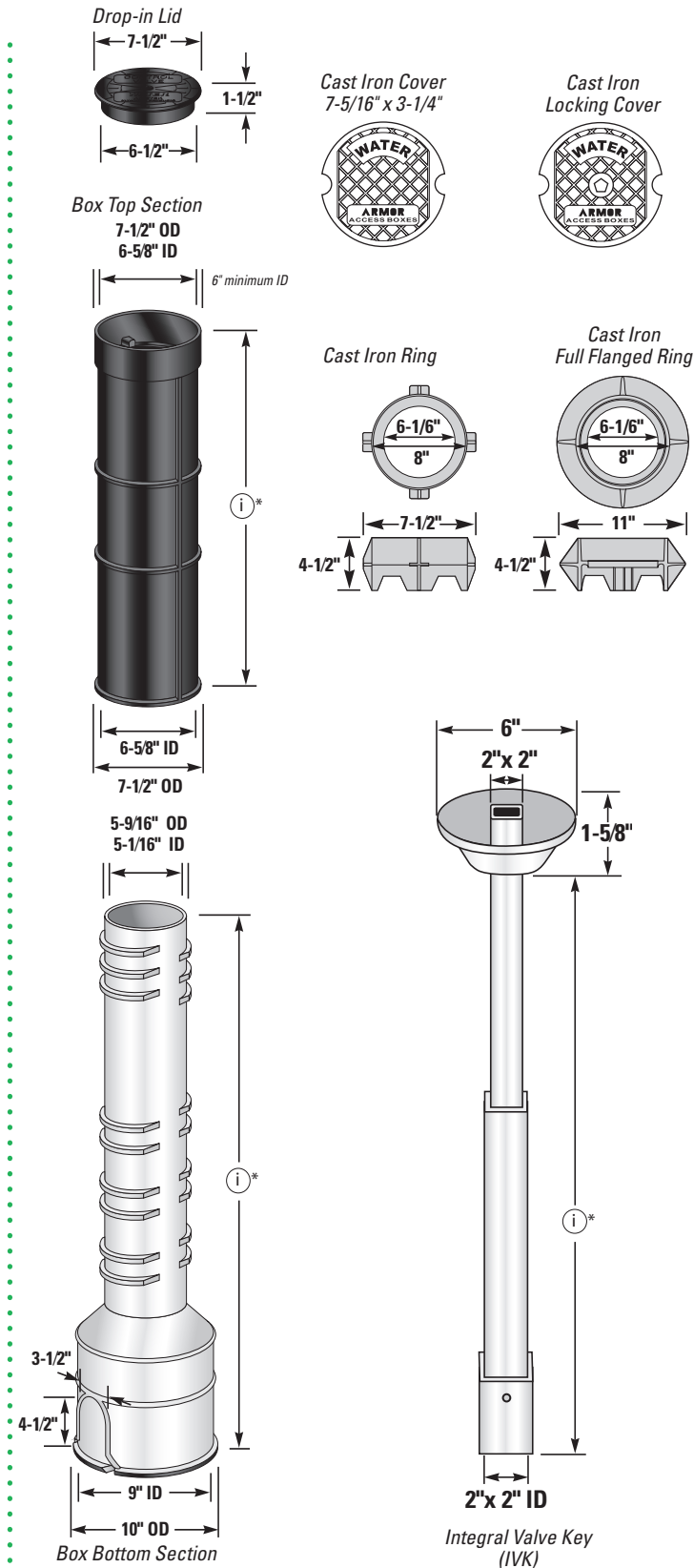

# PENTEK®

## ACCESS BOXES



# MAINLINE VALVE TURF BOXES

- 10 Year Lid Guarantee
- Interchangeable with most cast iron boxes
- One-third the weight of cast iron boxes
- Easy to store, handle and install
- Top section magnetically locatable
- Lids are easily interchangeable
- White bottom for improved valve visibility
- Available with cast iron rings and lids, or plastic drop-in lids (black or green)

*i*\* See reverse for available lengths

"You're Covered!"



# MAINLINE VALVE TURF BOXES

DESCRIPTION	WEIGHT	PART #	PART #	DESCR. #	EQUIVALENT CAST IRON #	ADJ. INCHES	TOTAL WEIGHT
<b>BOX BOTTOM SECTION</b>							
20" V.B. White Bottom	4 lbs	111048					
24" V.B. White Bottom	4-3/4 lbs	111049					
36" V.B. White Bottom	6-1/3 lbs	111050					
48" V.B. White Bottom	8 lbs	111051					
<b>BOX TOP SECTION</b>							
9-1/2" V.B. Black Top	2-1/2 lbs	111036					
15-1/2" V.B. Black Top	4 lbs	111037					
24-1/2" V.B. Black Top	6-3/4 lbs	111038					
<b>LIDS</b>							
<b>Control Valve</b>							
Green	1-7/8 lbs	111031					
<b>Water</b>							
Black	1-7/8 lbs	111030					
<b>EXTENSIONS</b>							
20" Adjustable	6-3/4 lbs	111146					
<b>INTEGRAL VALVE KEYS</b>							
26"-44" Integral Valve with Debris Cap	17-3/16 lbs	185003					
48"-80" Integral Valve with Debris Cap	20-7/8 lbs	185004					
<b>HEIGHT ADJUSTMENT TABLE</b>							
	<b>9-1/2" Top</b>	<b>15-1/2" Top</b>	<b>24-1/2" Top</b>				
20" Bottom	22" - 26"	25" - 31"	34" - 40"				
24" Bottom	26" - 30"	26" - 35"	34" - 44"				
36" Bottom	38" - 42"	38" - 47"	38" - 56"				
48" Bottom	50" - 54"	50" - 59"	50" - 68"				
Extension	Add 20 inches						
CI Ring	Add 2-1/2 inches						
If Knockouts Used	Subtract 4-1/2 inches to top of Pipe						
			<b>5-1/4" ROADWAY VALVE BOX</b>			(Add 2-1/2" for CI Ring)	
			<b>Total Plastic Box Including Ring &amp; Water Cover</b>				
			111129-01	5-95-20	462	22 - 26	26-1/3 lbs
			111130-01	5-155-20	561	25 - 31	27-3/4 lbs
			111130-03				
			111133-01	5-155-24	562	26 - 35	28-1/8 lbs
			111133-03				
			111136-01	5-155-36	564	38 - 47	29-7/8 lbs
			111136-03				
			111137-01	5-245-36	664	38 - 56	32-1/2 lbs
			111137-03				
			111140-01				
			111140-02	5-245-48	666	50 - 68	34-1/4 lbs
			111140-03				
			NOTE: Above Part Numbers use a two digit suffix to distinguish cover type. ("Water" cover will be shipped if no suffix number is specified.)				
			Plastic Top & Bottom Only -01				
			Full Flanged "Water" C.I. -02				
			"Water" C.I. -03				
			<b>PART #</b>	<b>DESCRIPTION</b>	<b>TOTAL WEIGHT</b>		
			<b>Cast Iron Top Parts</b>				
			111026	"Water" Cover	7-3/4 lbs		
			111028	CI Ring	11-1/2 lbs		
			111063	Full Flanged Ring (recommended for GAS)	14 lbs		
			111074	Locking "Water" Cover	9 lbs		
			NOTE: Polyiron® is a magnetically locatable material.				

## SUPERFLEXON BOXES AND COVERS

SUPERFLEXON is a plastic material made of a rigid combination of polyolefin and fibrous inorganic components. It is chemically inert and normally unaffected by moisture, corrosion and the effects of temperature changes. SUPERFLEXON also has a high tensile strength with light weight because it is a solid (not foamed) structural material.

SUPERFLEXON covers are NOT traffic covers and should not be used in roadways, etc.



502 Indiana Avenue, Sheboygan, WI 53081, USA  
 Phone: 800.348.7558 • Fax: 888.246.0085 • International Phone: 920.451.9469  
 E-mail: support@pentekaccessboxes.com • www.pentekaccessboxes.com